

SW/NW 2 3N 1E

APN MULTIPLE
CCW-24-146
WA722976
SER RLM

UTILITY EASEMENT

CITY OF PEORIA, (hereinafter called "Grantor"), is the owner of the following described real property located in Maricopa County, Arizona (hereinafter called "Grantor's Property"):

SEE EXHIBIT "A" ATTACHED HERETO AND MADE A PART HEREOF

Grantor, for and in consideration of One Dollar (\$1.00) and other valuable consideration, receipt of which is hereby acknowledged, does hereby grant and convey to **ARIZONA PUBLIC SERVICE COMPANY**, an Arizona corporation, (hereinafter called "Grantee"), and to its successors and assigns, a non-exclusive right, privilege, and easement at locations and elevations, in, upon, over, under, through and across, a portion of Grantor's Property described as follows (herein called the "Easement Premises"):

SEE EXHIBIT "B" ATTACHED HERETO AND MADE A PART HEREOF

Grantee is hereby granted the right within the Easement Premises to: construct, reconstruct, replace, repair, operate and maintain electrical lines, together with appurtenant facilities and fixtures for use in connection therewith, for the transmission and distribution of electricity to, through, across, and beyond Grantor's Property; install, operate and maintain telecommunication wires, cables, conduits, fixtures and facilities incidental to supplying electricity or for Grantee's own use (said electrical and telecommunication lines, facilities and fixtures collectively herein called "Grantee Facilities"); utilize the Easement Premises for all other purposes connected therewith.

Grantee is hereby granted the right, but not the obligation, to trim, prune, cut, and clear away trees, brush, shrubs, or other vegetation on, or adjacent to, the Easement Premises whenever in Grantee's judgment the same shall be necessary for the convenient and safe exercise of the rights herein granted.

Grantee shall at all times have the right of full and free ingress and egress to and along the Easement Premises for the purposes herein specified.

Grantor shall maintain clear areas that extend: 1) 3 feet from and around all edges of all switching cabinet pads and 2 feet from and around all edges of all transformer pads and other equipment pads, and 2) a clear operational area that extends 10 feet immediately in front of all transformer, switching cabinet and other equipment openings, and 3) a 6 feet by 6 feet hot-stick operating area off the front left corner of all transformers. No obstructions, trees, shrubs, large landscape rocks, fences, fixtures, or permanent structures shall be placed by Grantor within said clear areas; nor shall Grantor install landscape irrigation or sprinkler systems within said clear areas. Landscape irrigation or sprinkler systems installed adjacent to the clear areas shall be installed and maintained so that the transformers, switching cabinets or any other equipment do not get wet by spray or irrigation.

Grantor shall not locate, erect or construct, or permit to be located, erected or constructed, any building or other structure or drill any well within the limits of the Easement Premises; nor shall Grantor plant or permit to be planted any trees within the limits of the Easement Premises without the prior written consent of Grantee. However, Grantor reserves the right to use the Easement Premises for purposes that are not inconsistent with Grantee's easement rights herein conveyed and which do not interfere with or endanger any of the Grantee Facilities, including, without limitation, granting others the right to use all or portions of the Easement Premises for utility or roadway purposes and constructing improvements within the Easement Premises such as paving, sidewalks, landscaping, and curbing. Notwithstanding the foregoing, Grantor shall not have the right to lower by more than one foot or raise by more than two feet the surface grade of the Easement Premises, and in no event shall a change in the grade compromise Grantee's minimum cover requirements or interfere with Grantee's operation, maintenance or repair.

By accepting and utilizing this easement, Grantee agrees that following any installation, excavation, maintenance, repair, or other work by Grantee within the Easement Premises, the affected area will be restored by Grantee to as close to original condition as is reasonably practicable, at the expense of Grantee; and that Grantee shall indemnify Grantor, to the extent required by law, for any loss, cost or damage incurred by Grantor as a result of any negligent installation, excavation, maintenance, repair or other work performed by Grantee within the Easement Premises.

The easement granted herein shall not be deemed abandoned except upon Grantee's execution and recording of a formal instrument abandoning the easement.

The covenants and provisions herein set forth shall extend and inure in favor and to the benefit of, and shall be binding on the heirs, administrators, executors, successors in ownership and estate, assigns and lessees of Grantor and Grantee.

EXHIBIT “A”

LEGAL DESCRIPTION OF GRANTOR’S PROPERTY

LOT 11, LOT 12, LOT 14, FINAL PLAT PEORIA SPORTS COMPLEX, BOOK 1625 OF MAPS, PAGE 10, OFFICIAL RECORDS OF THE COUNTY RECORDER, MARICOPA COUNTY, ARIZONA.
(INSTR. #2021-1119620 M.C.R.)

-ALSO-

LOT 1, REPLAT OF PEORIA SPORTS COMPLEX, BOOK 1774 OF MAPS, PAGE 4, OFFICIAL RECORDS OF THE COUNTY RECORDER, MARICOPA COUNTY, ARIZONA.
(INSTR. #2023-0635931 M.C.R.)

July 25, 2024

LEGAL DESCRIPTION
ARIZONA PUBLIC SERVICE
ELECTRICAL EASEMENT
CITY OF PEORIA

THAT PORTION OF LOT 1, OF "REPLAT OF PEORIA SPORTS COMPLEX", AS RECORDED IN BOOK 1774 OF MAPS, PAGE 4, RECORDS OF MARICOPA COUNTY, ARIZONA, PORTION OF LOTS 11, 12, AND 14 OF "FINAL PLAT OF PEORIA SPORTS COMPLEX", AS RECORDED IN BOOK 1625 OF MAPS, PAGE 10, RECORDS OF MARICOPA COUNTY, ARIZONA BEING LOCATED IN SECTION 2, TOWNSHIP 3 NORTH, RANGE 1 EAST, OF THE GILA AND SALT RIVER MERIDIAN, MARICOPA COUNTY, ARIZONA, MORE PARTICULARLY DESCRIBED AS FOLLOWS:

LOT 1

PARCEL 1.

COMMENCING AT THE SOUTHWEST CORNER OF SAID LOT 1, FROM WHICH THE SOUTHEASTERLY CORNER OF SAID LOT 1 BEARS NORTH 49°59'42" EAST, A DISTANCE OF 650.31 FEET AS SHOWN IN BOOK 1774 OF MAPS, PAGE 4, MARICOPA COUNTY RECORDS;

THENCE NORTH 49°59'42" EAST, ALONG THE SOUTH LINE OF SAID LOT 1, A DISTANCE OF 370.80 FEET TO THE TRUE POINT OF BEGINNING;

THENCE DEPARTING SAID SOUTH LINE, NORTH 39°53'10" WEST, A DISTANCE OF 14.55 FEET;

THENCE SOUTH 50°06'50" WEST, A DISTANCE OF 9.11 FEET;
THENCE NORTH 39°53'10" WEST, A DISTANCE OF 27.65 FEET;
THENCE NORTH 50°06'50" EAST, A DISTANCE OF 12.94 FEET;
THENCE NORTH 24°27'11" WEST, A DISTANCE OF 6.05 FEET;
THENCE NORTH 40°03'16" WEST, A DISTANCE OF 165.22 FEET;
THENCE NORTH 42°02'43" WEST, A DISTANCE OF 35.22 FEET;
THENCE NORTH 50°37'26" WEST, A DISTANCE OF 78.76 FEET;
THENCE NORTH 45°47'08" WEST, A DISTANCE OF 43.43 FEET;
THENCE NORTH 34°00'06" WEST, A DISTANCE OF 103.30 FEET;

THENCE NORTH 39°21'33" WEST, A DISTANCE OF 96.12 FEET TO THE COMMON LINE BETWEEN LOT 1 AND LOT 11;

THENCE SOUTH 40°30'34" EAST, ALONG SAID COMMON LINE, A DISTANCE OF 68.82 FEET;
THENCE SOUTH 44°25'36" EAST, CONTINUING ALONG SAID COMMON LINE, A DISTANCE OF 50.70 FEET;

THENCE DEPARTING SAID COMMON LINE, SOUTH 34°00'28" EAST, A DISTANCE OF 79.88 FEET;

THENCE SOUTH 45°45'38" EAST, A DISTANCE OF 42.26 FEET;
THENCE SOUTH 50°36'42" EAST, A DISTANCE OF 69.44 FEET;
THENCE SOUTH 41°50'48" EAST, A DISTANCE OF 37.48 FEET;
THENCE NORTH 48°09'12" EAST, A DISTANCE OF 8.00 FEET;
THENCE NORTH 41°50'48" EAST, A DISTANCE OF 6.35 FEET;
THENCE NORTH 50°06'50" EAST, A DISTANCE OF 3.17 FEET;
THENCE NORTH 78°33'17" EAST, A DISTANCE OF 6.31 FEET;
THENCE SOUTH 41°50'48" EAST, A DISTANCE OF 11.98 FEET;
THENCE SOUTH 51°16'32" WEST, A DISTANCE OF 11.86 FEET;
THENCE SOUTH 40°03'16" EAST, A DISTANCE OF 171.04 FEET;
THENCE NORTH 50°06'50" EAST, A DISTANCE OF 3.65 FEET;
THENCE SOUTH 39°53'10" EAST, A DISTANCE OF 27.65 FEET;
THENCE SOUTH 50°06'50" WEST, A DISTANCE OF 9.11 FEET;
THENCE SOUTH 39°53'10" EAST, A DISTANCE OF 14.53 FEET TO THE SOUTH LINE OF SAID LOT 1;

THENCE SOUTH 49°59'42" WEST, ALONG SAID SOUTH LINE, A DISTANCE OF 8.00 FEET TO THE TRUE POINT OF BEGINNING.

CONTAINING 4,446.469 SQUARE FEET OR 0.102 ACRES, MORE OR LESS.

PARCEL 2.

COMMENCING AT THE NORTHWEST CORNER OF SAID LOT 12, FROM WHICH THE NORTHERN MOST EASTERLY CORNER OF SAID LOT 12 BEARS NORTH 49°59'21" EAST, A DISTANCE OF 608.72 FEET;

THENCE NORTH 49°59'21" EAST, ALONG THE COMMON LINE BETWEEN LOT 1 AND LOT 12, A DISTANCE OF 608.72 FEET TO THE BEGINNING OF A NON-TANGENT CURVE, CONCAVED NORTHERLY, WHOSE CENTER BEARS NORTH 10°22'25" EAST, A DISTANCE OF 448.60 FEET;

THENCE CONTINUING ALONG SAID COMMON LINE, EASTERLY, ALONG THE ARC OF SAID CURVE TO THE LEFT, THROUGH A CENTRAL ANGLE OF 09°21'42", A DISTANCE OF 73.30 FEET TO THE TRUE POINT OF BEGINNING;

THENCE DEPARTING SAID COMMON LINE, NORTH 50°45'14" EAST, A DISTANCE OF 20.33 FEET;
THENCE SOUTH 39°14'46" EAST, A DISTANCE OF 5.35 FEET;
THENCE NORTH 50°45'14" EAST, A DISTANCE OF 21.16 FEET;

THENCE SOUTH 47°38'48" EAST, A DISTANCE OF 16.85 FEET TO THE BEGINNING OF A NON-TANGENT CURVE, CONCAVE NORTHWESTERLY, WHOSE CENTER BEARS NORTH 05°13'36" WEST, A DISTANCE OF 439.60 FEET;

THENCE NORTHEASTERLY, ALONG THE ARC OF SAID CURVE, TO THE LEFT, THROUGH A CENTRAL ANGLE OF 37°46'56", A DISTANCE OF 289.88 FEET;

THENCE SOUTH 43°00'32" EAST, A DISTANCE OF 9.00 FEET TO THE NORTH LINE OF LOT 11, BEING THE BEGINNING OF A NON-TANGENT CURVE, CONCAVE NORTHWESTERLY, WHOSE CENTER BEARS NORTH 43°00'32" WEST, A DISTANCE OF 448.60 FEET;
THENCE SOUTHWESTERLY, ALONG THE ARC OF SAID CURVE TO THE RIGHT THROUGH A CENTRAL ANGLE OF 44°01'16", A DISTANCE OF 344.67 FEET TO THE TRUE POINT OF BEGINNING.

CONTAINING 3,213.767 SQUARE FEET OR 0.074 ACRES, MORE OR LESS.

LOT 11

PARCEL 1.

BEGINNING AT THE WESTERLY MOST NORTHERN CORNER OF SAID LOT 11, FROM WHICH THE SOUTHWEST CORNER OF SAID LOT 11 BEARS SOUTH 40°30'34" EAST, A DISTANCE OF 293.71 FEET ALSO BEING THE BEGINNING OF A NON-TANGENT CURVE, CONCAVE NORTHWESTERLY WHOSE CENTER BEARS NORTH 41°54'10" WEST, A DISTANCE OF 448.60 FEET;

THENCE NORTHEASTERLY, ALONG THE ARC OF SAID CURVE, TO THE LEFT, THROUGH A CENTRAL ANGLE OF 01°06'22", A DISTANCE OF 8.66 FEET;

THENCE SOUTH 43°03'52" EAST, A DISTANCE OF 59.83 FEET;
THENCE SOUTH 39°21'33" EAST, A DISTANCE OF 262.07 FEET;
THENCE SOUTH 34°00'28" EAST, A DISTANCE OF 22.94 FEET TO THE WEST LINE OF SAID LOT 11;

THENCE NORTH 44°25'36" WEST, ALONG SAID WEST LINE, A DISTANCE OF 50.70 FEET;

THENCE NORTH 40°30'34" WEST, CONTINUING ALONG SAID WEST LINE, A DISTANCE OF 293.71 FEET TO THE TRUE POINT OF BEGINNING.

CONTAINING 2,894.227 SQUARE FEET OR 0.066 ACRES, MORE OR LESS.

PARCEL 2.

COMMENCING AT THE MOST SOUTHERLY CORNER OF SAID LOT 11, FROM WHICH THE MOST EASTERLY CORNER OF SAID LOT 11 BEARS NORTH 49°58'37" EAST, A DISTANCE OF 657.05 FEET;

THENCE NORTH 49°58'37" EAST, ALONG THE SOUTHEASTERLY LINE OF SAID LOT 11, A DISTANCE OF 131.28 FEET TO THE TRUE POINT OF BEGINNING;

THENCE DEPARTING SAID SOUTHERLY LINE, NORTH 00°29'35" EAST, A DISTANCE OF 13.28 FEET;
THENCE NORTH 78°34'26" EAST, A DISTANCE OF 8.18 FEET;
THENCE SOUTH 00°29'35" EAST, A DISTANCE OF 8.13 FEET TO THE SOUTHERLY LINE OF SAID LOT 11;

THENCE SOUTH 49°58'37" WEST, ALONG SAID SOUTHERLY LINE, A DISTANCE OF 10.52 FEET TO THE TRUE POINT OF BEGINNING.

CONTAINING 85.645 SQUARE FEET OR 0.002 ACRES, MORE OR LESS.

LOT 12

PARCEL 1.

COMMENCING AT THE MOST WEST CORNER OF LOT 12, FROM WHICH THE NORTHERN MOST WESTERLY CORNER OF SAID LOT 12 BEARS NORTH 49°59'21" EAST, A DISTANCE OF 608.72 FEET;

THENCE NORTH 49°59'21" EAST, ALONG THE COMMON LINE BETWEEN LOT 1 AND LOT 12, A DISTANCE OF 608.72 FEET TO THE BEGINNING OF A NON-TANGENT CURVE, CONCAVE NORTHERLY, WHOSE CENTER BEARS NORTH 10°22'25" EAST, A DISTANCE OF 448.60 FEET;

THENCE EASTERLY, ALONG THE ARC OF SAID CURVE, TO THE LEFT, THROUGH A CENTRAL ANGLE OF 09°21'42", A DISTANCE OF 73.30 FEET TO THE TRUE POINT OF BEGINNING AND ALSO BEING A CONTINUATION ALONG SAID CURVE HAVING A RADIUS OF 448.60 FEET;

THENCE NORTHEASTERLY, ALONG THE ARC OF SAID CURVE, TO THE LEFT, THROUGH A CENTRAL ANGLE OF 10°56'34", A DISTANCE OF 85.68 FEET;

THENCE DEPARTING SAID NORTH LINE, SOUTH 75°51'01" WEST, A DISTANCE OF 45.46 FEET;

THENCE SOUTH 57°41'42" WEST, A DISTANCE OF 24.36 FEET;

THENCE SOUTH 77°48'31" WEST, A DISTANCE OF 17.16 FEET;

THENCE SOUTH 50°59'56" WEST, A DISTANCE OF 2.73 FEET;

THENCE SOUTH 00°00'00" EAST, A DISTANCE OF 25.88 FEET;

THENCE SOUTH 89°57'15" WEST, A DISTANCE OF 8.00 FEET;

THENCE NORTH 00°00'00" EAST, A DISTANCE OF 18.31 FEET;

THENCE NORTH 39°00'04" WEST, A DISTANCE OF 13.19 FEET;

THENCE NORTH 50°59'56" EAST, A DISTANCE OF 24.03 FEET;

THENCE NORTH 39°14'46" WEST, A DISTANCE OF 6.49 FEET TO THE TRUE POINT OF BEGINNING.

CONTAINING 1,089.392 SQUARE FEET OR 0.025 ACRES, MORE OR LESS.

LOT 14

PARCEL 1.

COMMENCING AT THE WEST MOST NORTHERLY CORNER OF LOT 14 ALSO BEING THE MOST SOUTHERLY CORNER OF LOT 12, FROM WHICH THE COMMON CORNER BETWEEN LOT 1, LOT 12 AND LOT 14 BEARS NORTH 49°58'30" EAST, A DISTANCE OF 608.43 FEET;

THENCE NORTH 49°58'30" EAST, ALONG THE NORTH LINE OF SAID LOT 14, A DISTANCE OF 600.07 FEET;

THENCE DEPARTING SAID NORTH LINE, SOUTH 40°01'30" EAST, A DISTANCE OF 22.77 FEET TO THE TRUE POINT OF BEGINNING;

THENCE NORTH 50°24'17" EAST, A DISTANCE OF 169.40 FEET;
THENCE NORTH 49°50'47" EAST, A DISTANCE OF 217.71 FEET;
THENCE SOUTH 39°53'10" EAST, A DISTANCE OF 3.00 FEET;
THENCE SOUTH 50°05'26" WEST, A DISTANCE OF 379.18 FEET;
THENCE SOUTH 00°00'00" EAST, A DISTANCE OF 72.49 FEET;
THENCE SOUTH 50°00'00" WEST, A DISTANCE OF 18.74 FEET;
THENCE SOUTH 40°00'00" WEST, A DISTANCE OF 5.69 FEET;
THENCE SOUTH 50°00'00" WEST, A DISTANCE OF 18.25 FEET;
THENCE NORTH 40°00'00" WEST, A DISTANCE OF 15.33 FEET;
THENCE NORTH 50°00'00" EAST, A DISTANCE OF 18.25 FEET;
THENCE SOUTH 40°00'00" EAST, A DISTANCE OF 1.64 FEET;
THENCE NORTH 50°00'00" EAST, A DISTANCE OF 15.01 FEET;

THENCE NORTH 00°00'00" EAST, A DISTANCE OF 65.98 FEET TO THE TRUE POINT OF BEGINNING.

CONTAINING 1,938.495 SQUARE FEET OR 0.045 ACRES, MORE OR LESS.

PARCEL 2.

COMMENCING AT THE WEST MOST NORTHERLY CORNER OF LOT 14 ALSO BEING THE MOST SOUTHERLY CORNER OF LOT 12, FROM WHICH THE COMMON CORNER BETWEEN LOT 1, LOT 12 AND LOT 14 BEARS NORTH 49°58'30" EAST, A DISTANCE OF 608.43 FEET;

THENCE NORTH 49°58'30" EAST, ALONG THE NORTH LINE OF SAID LOT 14, A DISTANCE OF 608.43 FEET;

THENCE NORTH 49°59'42" EAST, CONTINUING ALONG SAID NORTH LINE, A DISTANCE OF 370.80 FEET TO THE TRUE POINT OF BEGINNING;

THENCE NORTH 49°59'42" EAST, CONTINUING ALONG SAID NORTH LINE, A DISTANCE OF 8.00 FEET;

THENCE DEPARTING SAID NORTH LINE, SOUTH 39°53'10" EAST, A DISTANCE OF 15.42 FEET;

THENCE SOUTH 49°50'47" WEST, A DISTANCE OF 8.00 FEET;

THENCE NORTH 39°53'10" WEST, A DISTANCE OF 15.44 FEET TO THE TRUE POINT OF BEGINNING.

CONTAINING 123.454 SQUARE FEET OR 0.003 ACRES, MORE OR LESS.

PARCEL 3.

COMMENCING AT THE WEST MOST NORTHERLY CORNER OF LOT 14 ALSO BEING THE MOST SOUTHERLY CORNER OF LOT 12, FROM WHICH THE COMMON CORNER BETWEEN LOT 1, LOT 12 AND LOT 14 BEARS NORTH 49°58'30" EAST, A DISTANCE OF 608.43 FEET;

THENCE NORTH 49°58'30" EAST, ALONG THE NORTH LINE OF SAID LOT 14, A DISTANCE OF 608.43 FEET;

THENCE NORTH 49°59'42" EAST, CONTINUING ALONG SAID NORTH LINE, A DISTANCE OF 485.34 FEET;

THENCE DEPARTING SAID NORTH LINE, SOUTH 40°00'18" EAST, A DISTANCE OF 15.14 FEET TO THE TRUE POINT OF BEGINNING;

THENCE SOUTH 49°50'47" WEST, A DISTANCE OF 90.53 FEET;

THENCE NORTH 44°14'26" EAST, A DISTANCE OF 63.51 FEET;

THENCE NORTH 59°16'33" EAST, A DISTANCE OF 17.79 FEET;

THENCE NORTH 68°26'45" EAST, A DISTANCE OF 10.31 FEET TO THE TRUE POINT OF BEGINNING.

CONTAINING 295.422 SQUARE FEET OR 0.007 ACRES, MORE OR LESS

PARCEL 4.

COMMENCING AT THE WEST MOST NORTHERLY CORNER OF LOT 14 ALSO BEING THE MOST SOUTHERLY CORNER OF LOT 12, FROM WHICH THE COMMON CORNER BETWEEN LOT 1, LOT 12 AND LOT 14 BEARS NORTH 49°58'30" EAST, A DISTANCE OF 608.43 FEET;

THENCE NORTH 49°59'42" EAST, ALONG THE NORTH LINE OF SAID LOT 14, A DISTANCE OF 496.45 FEET;

THENCE DEPARTING SAID NORTH LINE, SOUTH 40°00'18" EAST, A DISTANCE OF 18.80 FEET TO THE TRUE POINT OF BEGINNING;

THENCE NORTH 65°43'16" EAST, A DISTANCE OF 70.64 FEET;

THENCE NORTH 55°17'24" EAST, A DISTANCE OF 88.19 FEET;

THENCE NORTH 47°02'48" EAST, A DISTANCE OF 94.19 FEET;

THENCE NORTH 00°29'35" EAST, A DISTANCE OF 54.25 FEET;

THENCE NORTH 49°58'37" EAST, A DISTANCE OF 10.52 FEET;

THENCE SOUTH 00°29'35" WEST, A DISTANCE OF 64.53 FEET;

THENCE SOUTH 47°02'48" WEST, A DISTANCE OF 98.21 FEET;

THENCE SOUTH 55°17'27" WEST, A DISTANCE OF 89.49 FEET;

THENCE SOUTH 65°43'16" WEST, A DISTANCE OF 73.28 FEET;

THENCE SOUTH 68°26'45" WEST, A DISTANCE OF 8.89 FEET;

THENCE NORTH 49°50'47" EAST, A DISTANCE OF 8.54 FEET;

THENCE NORTH 01°47'01" EAST, A DISTANCE OF 5.83 FEET TO THE TRUE POINT OF BEGINNING.

CONTAINING 2,548.538 SQUARE FEET OR 0.059 ACRES, MORE OR LESS.



NOTE: IT IS THE INTENT TO BE
COINCIDENT WITH THE EXISTING UTILITY
EASEMENT WITH NO GAP OR OVERLAP

CITY OF PEORIA
LOT 1
DOC. NO. 2023-0635931, MCR
BOOK 1774, PG 4 MCR
APN 200-53-973

CITY OF PEORIA
LOT 11
DOC. NO. 2021-1119620, MCR
BOOK 1625, PG 10 MCR
APN 200-53-951

APN 200-53-950

CITY OF PEORIA
LOT 12
DOC. NO. 2021-1119620, MCR
BOOK 1625, PG 10 MCR
APN 200-53-952

EX. 8' APS ESMT
DOC. NO. 2009-1136468
MCR

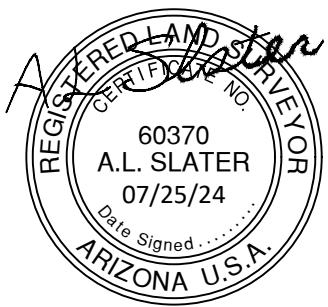
EX. 8' APS ESMT
DOC. NO. 2009-1136469
MCR

APN 200-53-953

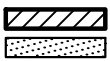
EX. 8' APS ESMT
DOC. NO. 2010-0934237
MCR

CITY OF PEORIA
LOT 14
DOC. NO. 2021-1119620, MCR
BOOK 1625, PG 10 MCR
APN 200-53-954

APN 200-53-955



LEGEND



- PROPERTY LINE
- PROPERTY CORNER
- MCR MARICOPA COUNTY RECORDS
- R/W RIGHT OF WAY
- EX. EXISTING
- ESMT EASEMENT

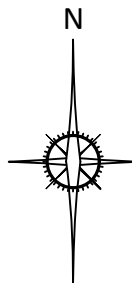


		EXHIBIT "B"	
JOB # WA722976		DATE: 7/25/2024	
SW 1/4 SEC 2 T3N R1E			
SCALE: 1" = 300'		INDEX: CCW-24-146	
R/W: S. REVORD			
SURVEY: J. SIEG			
DRAWN BY: N. STEELS		SHEET 8 OF 22	

LOT 1
STADIUM WAY

CITY OF PEORIA
LOT 1

DOC. NO. 2023-0635931, MCR
BOOK 1774, PG 4 MCR
APN 200-53-973

LOT 11
APN 200-53-951

EX. 8' APS ESMT
DOC. NO. 2009-1136468
MCR

LOT 12
APN 200-53-952

SEE DETAIL "A"
ON SHEET 10

LOT 1

LOT 14
APN 200-53-954



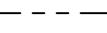
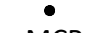
EX. 8' APS ESMT
DOC. NO. 2010-0934237
MCR

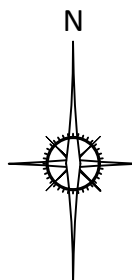
MARINERS WAY
N49°59'21"E 608.72'
60' R/W


SEE DETAIL "B"
ON SHEET 11







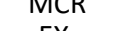
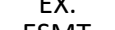

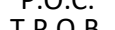
LEGEND

-  EASEMENT AREA
-  EXISTING EASEMENT
-  PROPERTY LINE
-  PROPERTY CORNER
- MCR MARICOPA COUNTY RECORDS
- R/W RIGHT OF WAY
- EX. EXISTING
- ESMT EASEMENT

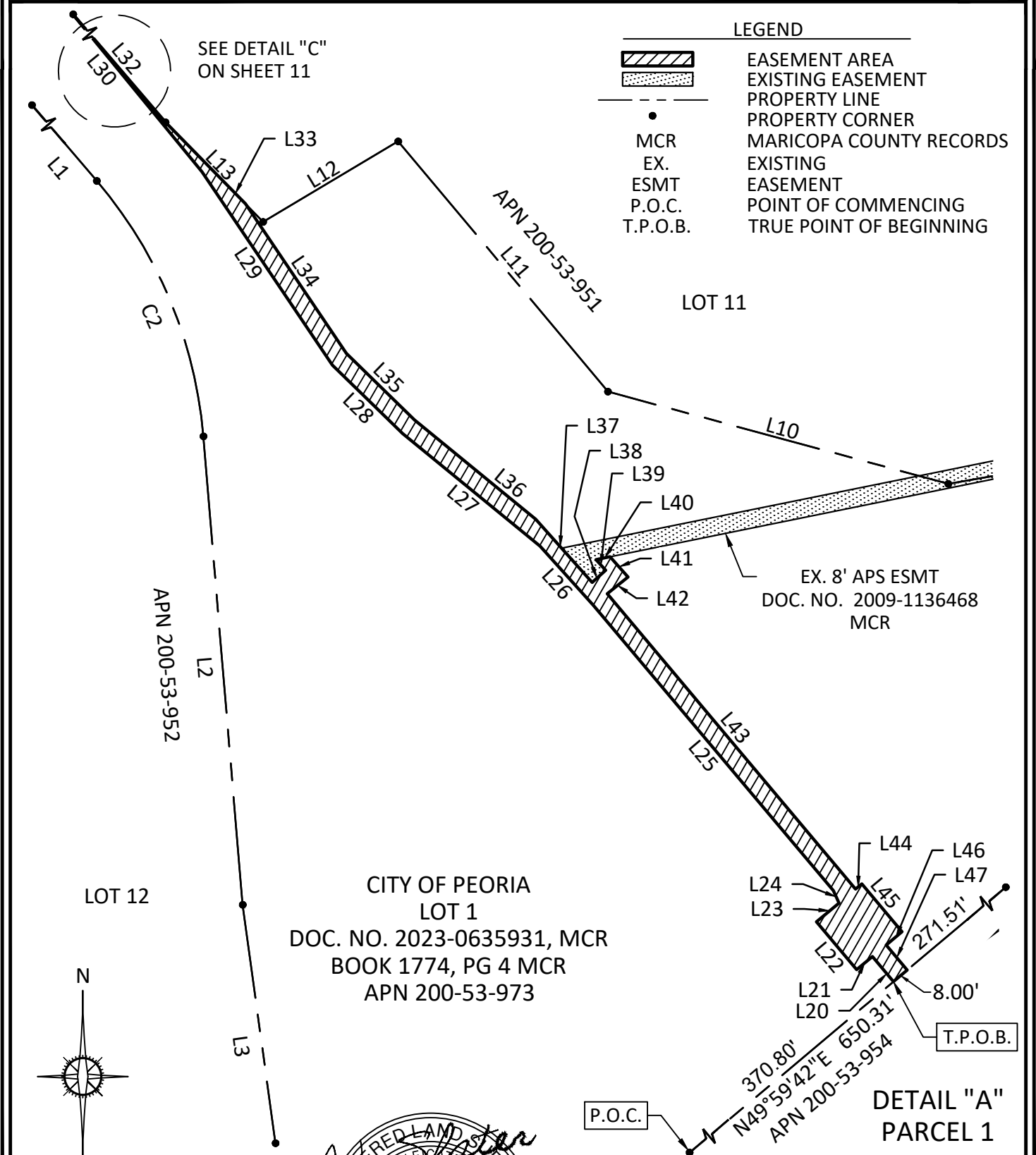


		EXHIBIT "B"	
JOB # WA722976		DATE: 7/25/2024	
SW 1/4 SEC 2 T3N R1E			
SCALE: 1" = 200'		INDEX: CCW-24-146	
R/W: S. REVORD			
SURVEY: J. SIEG			
DRAWN BY: N. STEELS		SHEET 9 OF 22	

LEGEND

-  EASEMENT AREA
-  EXISTING EASEMENT
-  PROPERTY LINE
-  PROPERTY CORNER
-  MCR
-  EX. ESMT
-  P.O.C.
-  T.P.O.B.

SEE DETAIL "C"
ON SHEET 11

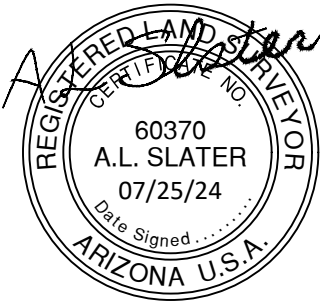


LOT 12

CITY OF PEORIA
LOT 1
DOC. NO. 2023-0635931, MCR
BOOK 1774, PG 4 MCR
APN 200-53-973


EX. 8' APS ESMT
DOC. NO. 2009-1136468
MCR

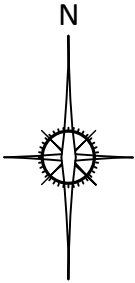
DETAIL "A"
PARCEL 1



P.O.C.

T.P.O.B.

	EXHIBIT "B"
JOB # WA722976	DATE: 7/25/2024
SW 1/4 SEC 2 T3N R1E	
SCALE: 1" = 60'	INDEX: CCW-24-146
R/W: S. REVORD	
SURVEY: J. SIEG	
DRAWN BY: N. STEELS	SHEET 10 OF 22



CITY OF PEORIA
 LOT 1
 DOC. NO. 2023-0635931, MCR
 BOOK 1774, PG 4 MCR
 APN 200-53-973

LOT 12
 APN 200-53-952

LOT 11
 APN 200-53-951

DETAIL "B"
 PARCEL 2
 SCALE 1" = 60'

CITY OF PEORIA
 LOT 1
 DOC. NO. 2023-0635931, MCR
 BOOK 1774, PG 4 MCR
 APN 200-53-973

LOT 11
 APN 200-53-951

DETAIL "C"
 PARCEL 1
 SCALE 1" = 20'



LEGEND



EASEMENT AREA



PROPERTY LINE



PROPERTY CORNER

MCR

MARICOPA COUNTY RECORDS

P.O.C.

POINT OF COMMENCING

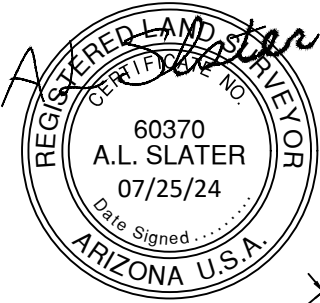
T.P.O.B.

TRUE POINT OF BEGINNING



EXHIBIT "B"

JOB # WA722976	DATE: 7/25/2024
SW 1/4 SEC 2 T3N R1E	
SCALE: NONE	INDEX: CCW-24-146
R/W: S. REVORD	
SURVEY: J. SIEG	
DRAWN BY: N. STEELS	SHEET 11 OF 22



PADRES WAY
 N50°00'41"E 616.60'

LOT 1
 APN 200-53-973

CITY OF PEORIA
 LOT 11
 DOC. NO. 2021-1119620, MCR
 BOOK 1625, PG 10 MCR
 APN 200-53-951

LOT 11
 APN 200-53-950
 S39°41'20"E 953.95'

50' R/W

C6

SEE DETAIL "D"
 ON SHEET 13

LOT 12

LOT 1
 APN 200-53-973



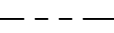




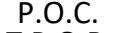






EX. 8' APS ESMT
 DOC. NO. 2009-1136468
 MCR

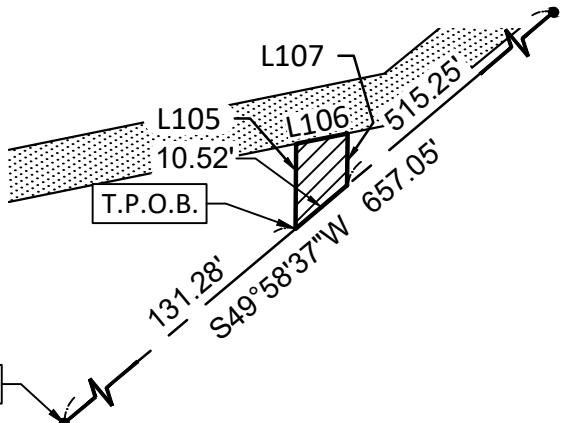
EX. 8' APS ESMT
 DOC. NO. 2009-1136469
 MCR

SEE DETAIL "E"
 BELOW

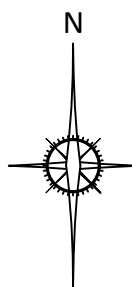
LOT 14
 APN 200-53-954


LEGEND

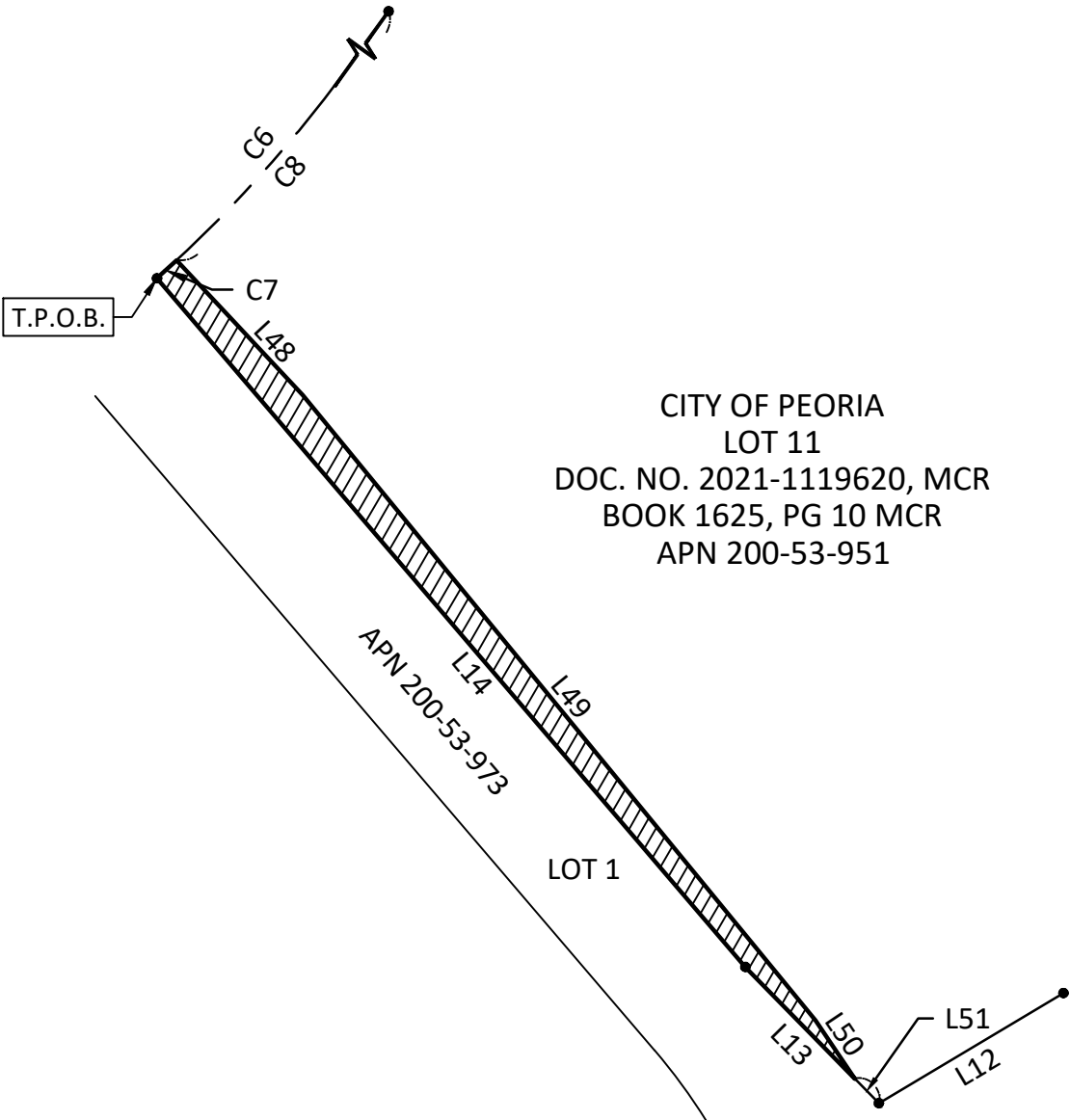
-  EASEMENT AREA
-  EXISTING EASEMENT
-  PROPERTY LINE
-  PROPERTY CORNER
-  MCR
-  EX.
-  ESMT
-  P.O.C.
-  T.P.O.B.
-  MARICOPA COUNTY RECORDS
-  EXISTING
-  EASEMENT
-  POINT OF COMMENCING
-  TRUE POINT OF BEGINNING



DETAIL "E"
PARCEL 2
SCALE 1" = 30'



		EXHIBIT "B"	
JOB # WA722976		DATE: 7/25/2024	
SW 1/4 SEC 2 T3N R1E			
SCALE: 1" = 200'		INDEX: CCW-24-146	
R/W: S. REVORD			
SURVEY: J. SIEG			
DRAWN BY: N. STEELS		SHEET 12 OF 22	



CITY OF PEORIA
 LOT 11
 DOC. NO. 2021-1119620, MCR
 BOOK 1625, PG 10 MCR
 APN 200-53-951

DETAIL "D"
 PARCEL 1



LEGEND	
	EASEMENT AREA
	PROPERTY LINE
	PROPERTY CORNER
MCR	MARICOPA COUNTY RECORDS
T.P.O.B.	TRUE POINT OF BEGINNING

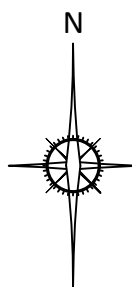
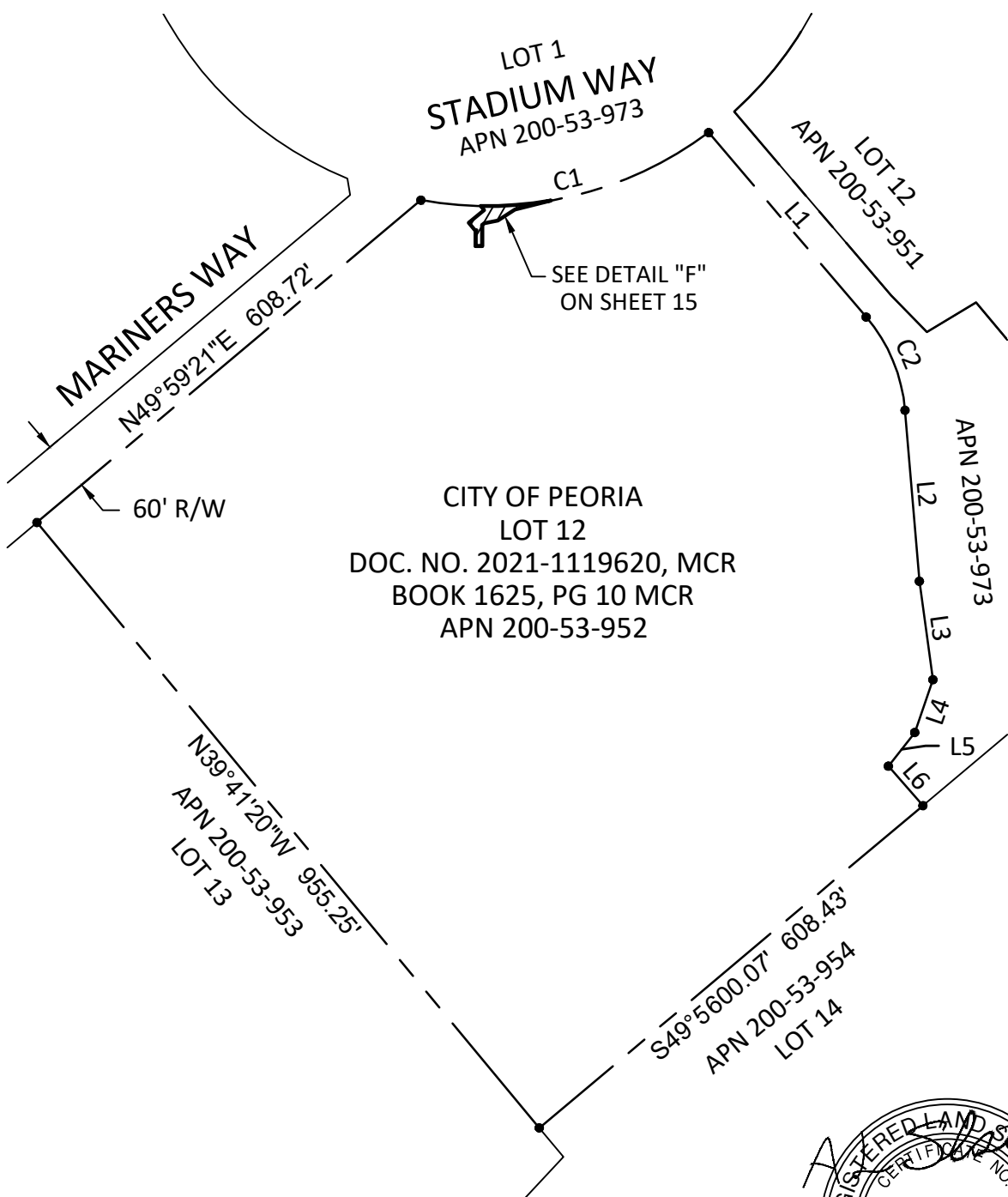



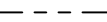



	EXHIBIT "B"
JOB # WA722976	DATE: 7/25/2024
SW 1/4 SEC 2 T3N R1E	
SCALE: 1" = 60'	INDEX: CCW-24-146
R/W: S. REVORD	
SURVEY: J. SIEG	
DRAWN BY: N. STEELS	SHEET 13 OF 22

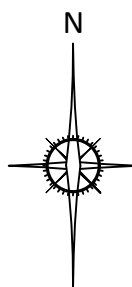



CITY OF PEORIA
 LOT 12
 DOC. NO. 2021-1119620, MCR
 BOOK 1625, PG 10 MCR
 APN 200-53-952

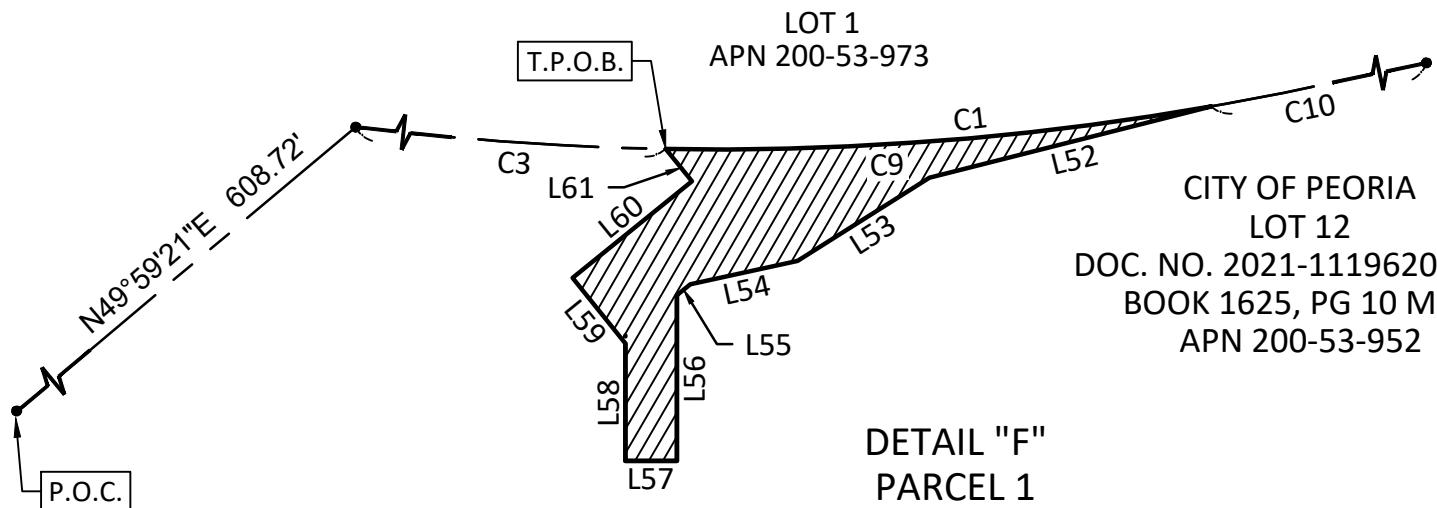
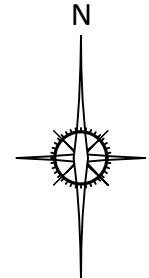


LEGEND

-  EASEMENT AREA
-  PROPERTY LINE
-  PROPERTY CORNER
-  MARICOPA COUNTY RECORDS
-  RIGHT OF WAY



		EXHIBIT "B"	
JOB # WA722976		DATE: 7/25/2024	
SW 1/4 SEC 2 T3N R1E			
SCALE: 1" = 200'		INDEX: CCW-24-146	
R/W: S. REVORD			
SURVEY: J. SIEG			
DRAWN BY: N. STEELS		SHEET 14 OF 22	



CITY OF PEORIA
LOT 12
DOC. NO. 2021-1119620, MCR
BOOK 1625, PG 10 MCR
APN 200-53-952

DETAIL "F"
PARCEL 1
SCALE 1" = 30'



LEGEND


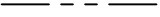

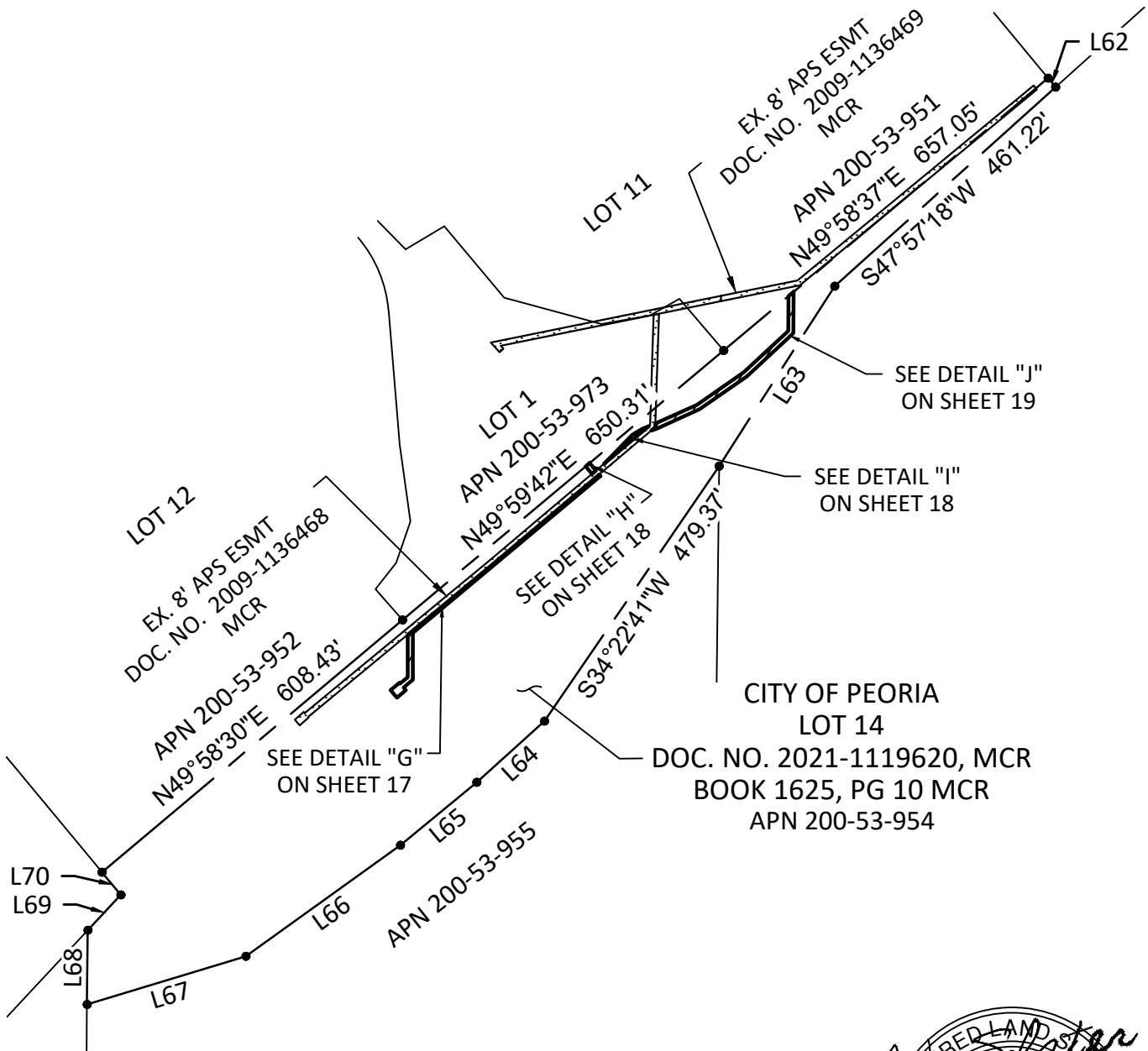
-  EASEMENT AREA
-  PROPERTY LINE
-  PROPERTY CORNER
- MCR MARICOPA COUNTY RECORDS
- P.O.C. POINT OF COMMENCING
- T.P.O.B. TRUE POINT OF BEGINNING

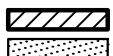


EXHIBIT "B"

JOB # WA722976	DATE: 7/25/2024
SW 1/4 SEC 2 T3N R1E	
SCALE: NONE	INDEX: CCW-24-146
R/W: S. REVORD	
SURVEY: J. SIEG	
DRAWN BY: N. STEELS	SHEET 15 OF 22



LEGEND



EASEMENT AREA
EXISTING EASEMENT



PROPERTY LINE
PROPERTY CORNER

MCR
EX.
ESMT

MARICOPA COUNTY RECORDS
EXISTING
EASEMENT

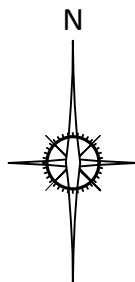


		EXHIBIT "B"	
JOB # WA722976		DATE: 7/25/2024	
SW 1/4 SEC 2 T3N R1E			
SCALE: 1" = 250'		INDEX: CCW-24-146	
R/W: S. REVORD			
SURVEY: J. SIEG			
DRAWN BY: N. STEELS		SHEET 16 OF 22	

EX. 8' APS ESMT
 DOC. NO. 2010-0934237
 MCR

LOT 1
 APN 200-53-973
 N49°59'42"E 650.31'

SEE BELOW RIGHT

DETAIL "G"
 PARCEL 1

SEE ABOVE LEFT

EX. 8' APS ESMT
 DOC. NO. 2010-0934237
 MCR

LOT 1
 APN 200-53-973
 N49°59'42"E 650.31'

CITY OF PEORIA
 LOT 14
 DOC. NO. 2021-1119620, MCR
 BOOK 1625, PG 10 MCR
 APN 200-53-954

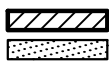
LOT 12
 APN 200-53-952
 N49°58'30"E 608.43'
 600.07'

T.P.O.B.

P.O.C.



LEGEND



MCR MARICOPA COUNTY RECORDS
 P.O.C. POINT OF COMMENCING
 T.P.O.B. TRUE POINT OF BEGINNING
 EX. EXISTING
 ESMT EASEMENT

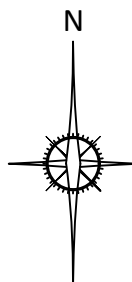
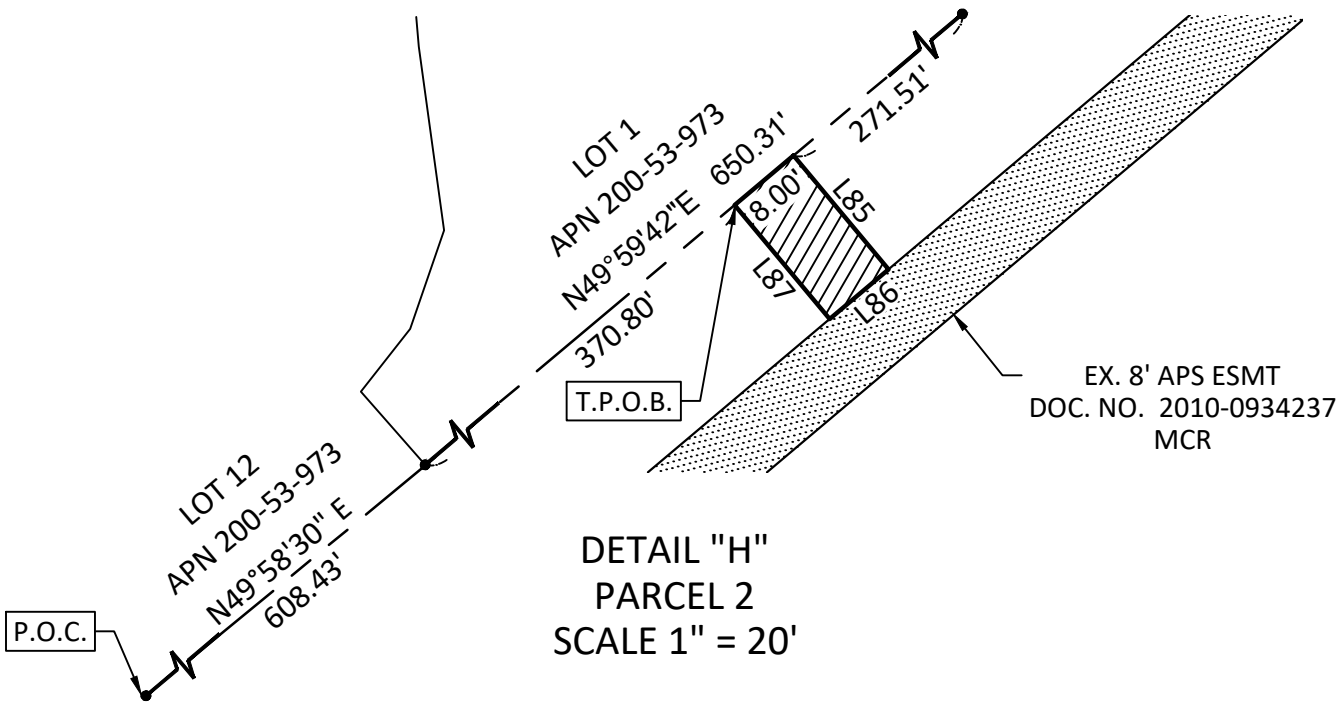
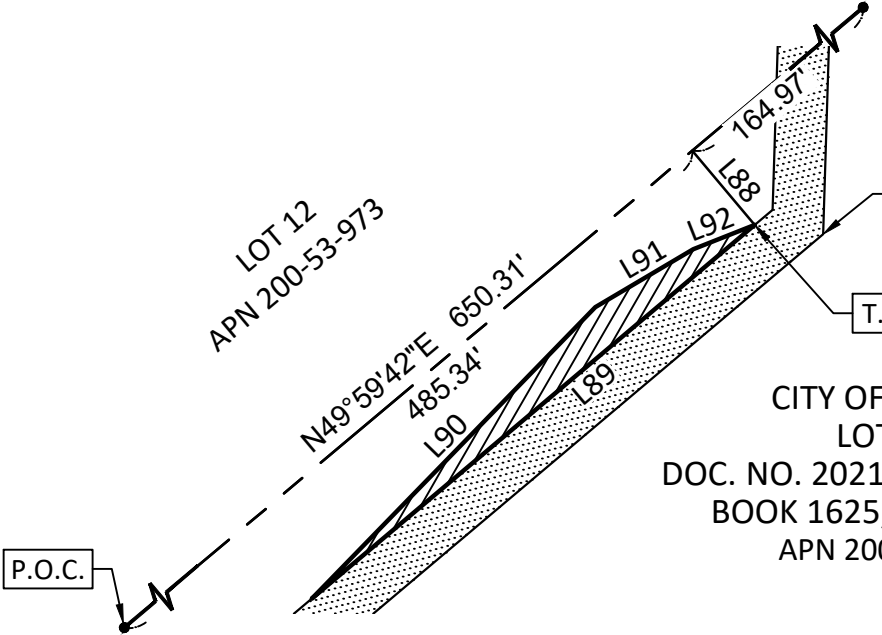


		EXHIBIT "B"	
JOB # WA722976		DATE: 7/25/2024	
SW 1/4 SEC 2 T3N R1E			
SCALE: 1" = 50'		INDEX: CCW-24-146	
R/W: S. REVORD			
SURVEY: J. SIEG			
DRAWN BY: N. STEELS		SHEET 17 OF 22	



DETAIL "H"
PARCEL 2
SCALE 1" = 20'

EX. 8' APS ESMT
DOC. NO. 2010-0934237
MCR





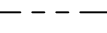

DETAIL "I"
PARCEL 3
SCALE 1" = 30'

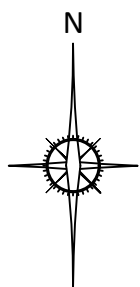
EX. 8' APS ESMT
DOC. NO. 2010-0934237
MCR


CITY OF PEORIA
LOT 14
DOC. NO. 2021-1119620, MCR
BOOK 1625, PG 10 MCR
APN 200-53-954



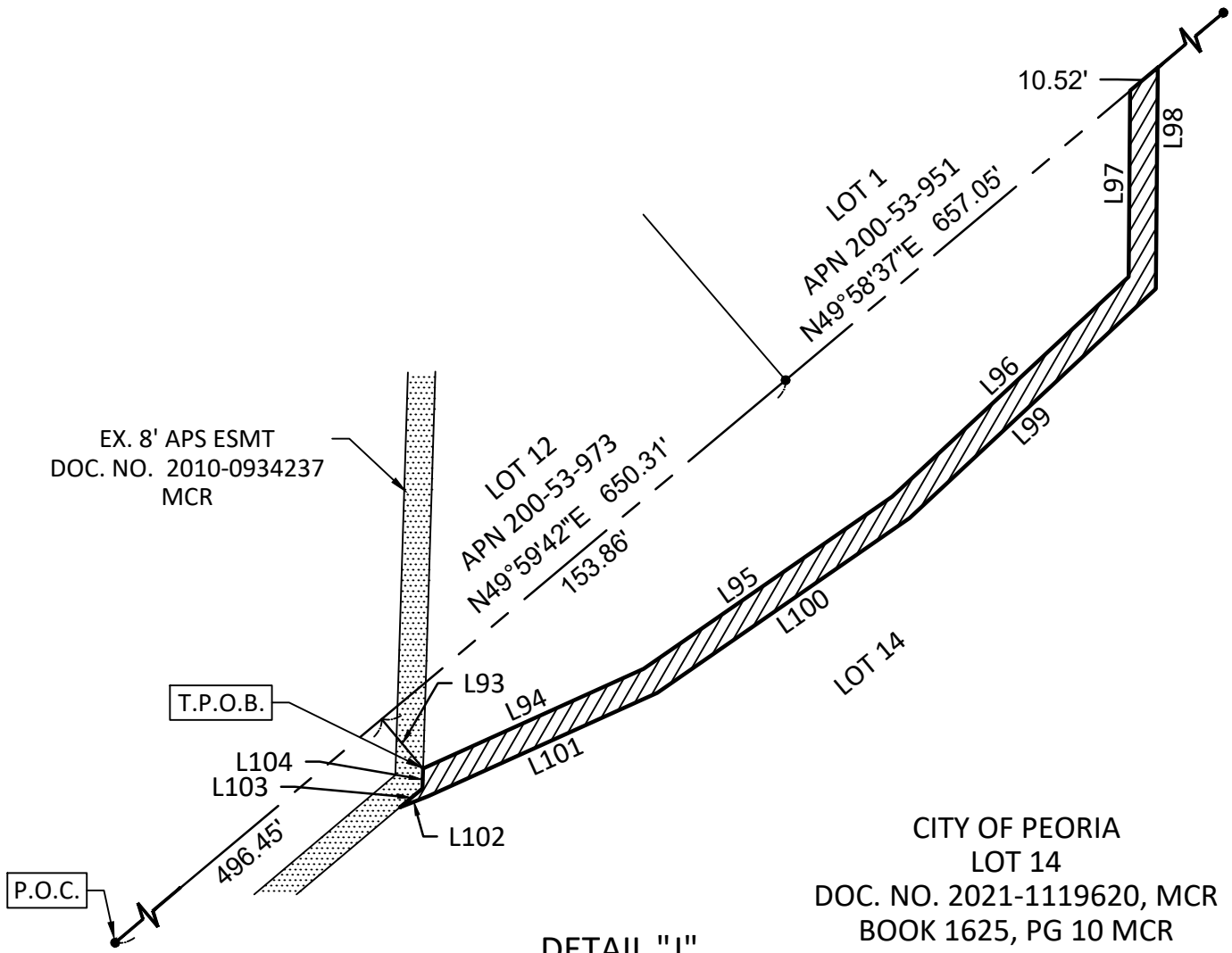
LEGEND

-  EASEMENT AREA
-  EXISTING EASEMENT
-  PROPERTY LINE
-  PROPERTY CORNER
- MCR MARICOPA COUNTY RECORDS
- P.O.C. POINT OF COMMENCING
- T.P.O.B. TRUE POINT OF BEGINNING
- EX. EXISTING
- ESMT EASEMENT



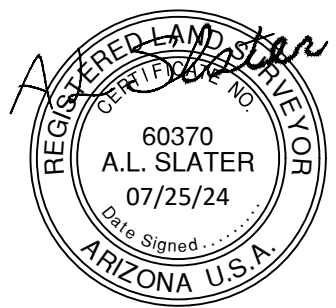
	EXHIBIT "B"
JOB # WA722976	DATE: 7/25/2024
SW 1/4 SEC 2 T3N R1E	
SCALE: 1" = 50'	INDEX: CCW-24-146
R/W: S. REVORD	
SURVEY: J. SIEG	
DRAWN BY: N. STEELS	SHEET 18 OF 22

EX. 8' APS ESMT
 DOC. NO. 2010-0934237
 MCR



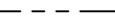











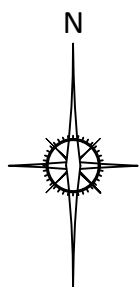
CITY OF PEORIA
 LOT 14
 DOC. NO. 2021-1119620, MCR
 BOOK 1625, PG 10 MCR
 APN 200-53-954


DETAIL "J"
 PARCEL 4



LEGEND

-  EASEMENT AREA
-  EXISTING EASEMENT
-  PROPERTY LINE
-  PROPERTY CORNER
-  MCR
-  P.O.C.
-  T.P.O.B.
-  EX.
-  ESMT
-  MARICOPA COUNTY RECORDS
-  POINT OF COMMENCING
-  TRUE POINT OF BEGINNING



	EXHIBIT "B"
JOB # WA722976	DATE: 7/25/2024
SW 1/4 SEC 2 T3N R1E	
SCALE: 1" = 50'	INDEX: CCW-24-146
R/W: S. REVORD	
SURVEY: J. SIEG	
DRAWN BY: N. STEELS	SHEET 19 OF 22


LINE TABLE		
NO.	BEARING	LENGTH
L1	S40°30'34"E	294.52
L2	S04°47'29"E	208.35
L3	S07°50'48"E	120.60
L4	S19°00'59"W	67.85
L5	S38°05'13"W	51.93
L6	S41°13'56"E	63.71
L7	N40°38'21"W	105.72
L8	S60°02'03"W	52.07
L9	S80°02'53"W	76.92
L10	N74°50'24"W	156.27
L11	N39°57'45"W	144.73
L12	S59°11'29"W	69.71
L13	N44°25'36"W	61.83
L14	N40°30'34"W	293.71
L15	N50°45'14"E	20.33

LINE TABLE		
NO.	BEARING	LENGTH
L16	S39°14'46"E	5.35
L17	N50°45'14"E	21.16
L18	S47°38'48"E	16.85
L19	S43°00'32"E	9.00
L20	N39°53'10"W	14.55
L21	S50°06'50"W	9.11
L22	N39°53'10"W	27.65
L23	N50°06'50"E	12.94
L24	N24°27'11"W	6.05
L25	N40°03'16"W	165.22
L26	N42°02'43"W	35.22
L27	N50°37'26"W	78.76
L28	N45°47'08"W	43.43
L29	N34°00'06"W	103.30
L30	N39°21'33"W	96.12

LINE TABLE		
NO.	BEARING	LENGTH
L31	N40°30'34"W	224.89
L32	S40°30'34"E	68.82
L33	S44°25'36"E	50.70
L34	S34°00'28"E	79.88
L35	S45°45'38"E	42.26
L36	S50°36'42"E	69.44
L37	S41°50'48"E	37.48
L38	N48°09'12"E	8.00
L39	N41°50'48"W	6.35
L40	N78°33'17"E	6.31
L41	S41°50'48"E	11.98
L42	S51°16'32"W	11.86
L43	S40°03'16"E	171.04
L44	N50°06'50"E	3.65
L45	S39°53'10"E	27.65

LINE TABLE		
NO.	BEARING	LENGTH
L46	S50°06'50"W	9.11
L47	S39°53'10"E	14.53
L48	S43°03'52"E	59.83
L49	S39°21'33"E	262.07
L50	S34°00'28"E	22.94
L51	S44°25'36"E	11.13
L52	S75°51'01"W	45.46
L53	S57°41'42"W	24.36
L54	S77°48'31"W	17.16
L55	S50°59'56"W	2.73
L56	S00°00'00"E	25.88
L57	S89°57'15"W	8.00
L58	N00°00'00"E	18.31
L59	N39°00'04"W	13.19
L60	N50°59'56"E	24.03



	EXHIBIT "B"
JOB # WA722976 DATE: 7/25/2024	
SW 1/4 SEC 2 T3N R1E	
SCALE: NONE	INDEX: CCW-24-146
R/W: S. REVORD	
SURVEY: J. SIEG	
DRAWN BY: N. STEELS	SHEET 20 OF 22

LINE TABLE		
NO.	BEARING	LENGTH
L61	N39°14'46"W	6.49
L62	S39°41'20"E	18.15
L63	S32°44'05"W	331.77
L64	S47°55'34"W	141.59
L65	S50°28'01"W	153.38
L66	S54°17'45"W	295.18
L67	S73°06'51"W	257.33
L68	N00°35'49"E	115.17
L69	N43°02'29"E	74.97
L70	N39°41'20"W	45.79
L71	S40°01'30"E	22.77
L72	N50°24'17"E	169.40
L73	N49°50'47"E	217.71
L74	S39°53'10"E	3.00
L75	S50°05'26"W	379.18

LINE TABLE		
NO.	BEARING	LENGTH
L76	S00°00'00"E	72.49
L77	S50°00'00"W	18.74
L78	S40°00'00"E	5.69
L79	S50°00'00"W	18.25
L80	N40°00'00"W	15.33
L81	N50°00'00"E	18.25
L82	S40°00'00"E	1.64
L83	N50°00'00"E	15.01
L84	N00°00'00"E	65.98
L85	S39°53'10"E	15.42
L86	S49°50'47"W	8.00
L87	N39°53'10"W	15.44
L88	S40°00'18"E	15.14
L89	S49°50'47"W	90.53
L90	N44°14'26"E	63.51

LINE TABLE		
NO.	BEARING	LENGTH
L91	N59°16'33"E	17.79
L92	N68°26'45"E	10.31
L93	S40°00'18"E	18.80
L94	N65°43'16"E	70.64
L95	N55°17'24"E	88.19
L96	N47°02'48"E	94.19
L97	N00°29'35"E	54.25
L98	S00°29'35"W	64.53
L99	S47°02'48"W	98.21
L100	S55°17'24"W	89.49
L101	S65°43'16"W	73.28
L102	S68°26'45"W	8.89
L103	N49°50'47"E	8.54
L104	N01°47'01"E	5.83
L105	N00°29'35"E	13.28


LINE TABLE		
NO.	BEARING	LENGTH
L106	N78°34'26"E	8.18
L107	S00°29'35"W	8.13



aps	EXHIBIT "B"
JOB # WA722976 DATE: 7/25/2024	
SW 1/4 SEC 2 T3N R1E	
SCALE: NONE	INDEX: CCW-24-146
R/W: S. REVORD	
SURVEY: J. SIEG	
DRAWN BY: N. STEELS	SHEET 21 OF 22

CURVE TABLE						
NO.	LENGTH	RADIUS	DELTA	TANGENT	CHORD	CHORD-BEARING
C1	369.27'	448.60'	047°09'48"	195.82'	358.93'	N76°47'31"E
C2	124.68'	200.00'	035°43'06"	64.44'	122.67'	S22°39'01"E
C3	73.30'	448.60'	009°21'42"	36.73'	73.22'	S84°18'26"E
C4	289.88'	439.60'	037°46'56"	150.43'	284.66'	N65°52'56"E
C5	344.67'	448.60'	044°01'16"	181.34'	336.25'	S69°00'06"W
C6	378.61'	448.60'	048°21'24"	201.40'	367.47'	N23°55'13"E
C7	8.66'	448.60'	001°06'22"	4.33'	8.66'	N47°32'44"E
C8	369.95'	448.60'	047°15'02"	196.22'	359.56'	N23°22'02"E
C9	85.68'	448.60'	010°56'34"	42.97'	85.55'	N85°32'27"E
C10	210.29'	448.60'	026°51'29"	107.11'	208.37'	N66°38'25"E



	EXHIBIT "B"
JOB # WA722976 DATE: 7/25/2024	
SW 1/4 SEC 2 T3N R1E	
SCALE: NONE	INDEX: CCW-24-146
R/W: S. REVORD	
SURVEY: J. SIEG	
DRAWN BY: N. STEELS	SHEET 22 OF 22

Parcel Map Check Report

Arizona Public Service

City of Peoria

Date: 7/25/2024

Lot 1 Parcel 1

Segment# 1: Line

Course: N39° 53' 10.47"W

North: 3,258.1560'

Length: 14.551'

East: -7,408.7029'

Segment# 2: Line

Course: S50° 06' 49.53"W

North: 3,252.3141'

Length: 9.110'

East: -7,415.6931'

Segment# 3: Line

Course: N39° 53' 10.47"W

North: 3,273.5343'

Length: 27.655'

East: -7,433.4273'

Segment# 4: Line

Course: N50° 06' 49.53"E

North: 3,281.8342'

Length: 12.943'

East: -7,423.4959'

Segment# 5: Line

Course: N24° 27' 11.04"W

North: 3,287.3397'

Length: 6.048'

East: -7,425.9995'

Segment# 6: Line

Course: N40° 03' 15.98"W

North: 3,413.8069'

Length: 165.223'

East: -7,532.3230'

Segment# 7: Line

Course: N42° 02' 42.67"W

North: 3,439.9648'

Length: 35.224'

East: -7,555.9131'

Segment# 8: Line

Course: N50° 37' 25.51"W

North: 3,489.9291'

Length: 78.757'

East: -7,616.7920'

Segment# 9: Line
Course: N45° 47' 07.92"W Length: 43.432'
North: 3,520.2162' East: -7,647.9212'

Segment# 10: Line
Course: N34° 00' 05.87"W Length: 103.296'
North: 3,605.8508' East: -7,705.6860'

Segment# 11: Line
Course: N39° 21' 33.08"W Length: 96.119'
North: 3,680.1686' East: -7,766.6428'

Segment# 12: Line
Course: S40° 30' 34.00"E Length: 68.818'
North: 3,627.8464' East: -7,721.9404'

Segment# 13: Line
Course: S44° 25' 36.00"E Length: 50.705'
North: 3,591.6356' East: -7,686.4471'

Segment# 14: Line
Course: S34° 00' 27.78"E Length: 79.876'
North: 3,525.4214' East: -7,641.7721'

Segment# 15: Line
Course: S45° 45' 37.63"E Length: 42.264'
North: 3,495.9355' East: -7,611.4930'

Segment# 16: Line
Course: S50° 36' 41.52"E Length: 69.440'
North: 3,451.8706' East: -7,557.8255'

Segment# 17: Line
Course: S41° 50' 48.26"E Length: 37.477'
North: 3,423.9528' East: -7,532.8231'

Segment# 18: Line

Course: N48° 09' 11.74"E Length: 8.000'
North: 3,429.2899' East: -7,526.8636'

Segment# 19: Line
Course: N41° 50' 48.26"W Length: 6.350'
North: 3,434.0202' East: -7,531.0999'

Segment# 20: Line
Course: N78° 33' 16.74"E Length: 6.313'
North: 3,435.2729' East: -7,524.9125'

Segment# 21: Line
Course: S41° 50' 48.26"E Length: 11.976'
North: 3,426.3516' East: -7,516.9228'

Segment# 22: Line
Course: S51° 16' 32.24"W Length: 11.863'
North: 3,418.9304' East: -7,526.1779'

Segment# 23: Line
Course: S40° 03' 15.98"E Length: 171.043'
North: 3,288.0084' East: -7,416.1091'

Segment# 24: Line
Course: N50° 06' 49.53"E Length: 3.646'
North: 3,290.3465' East: -7,413.3115'

Segment# 25: Line
Course: S39° 53' 10.47"E Length: 27.655'
North: 3,269.1263' East: -7,395.5773'

Segment# 26: Line
Course: S50° 06' 49.53"W Length: 9.105'
North: 3,263.2875' East: -7,402.5637'

Segment# 27: Line
Course: S39° 53' 10.47"E Length: 14.535'

North: 3,252.1346'

East: -7,393.2429'

Segment# 28: Line

Course: S49° 59' 42.00"W

Length: 8.000'

North: 3,246.9917'

East: -7,399.3708'

Perimeter: 1,219.426'

Area: 4,446.47Sq.Ft.

Error Closure: 0.0014

Course: N45° 19' 50.44"E

Error North : 0.00096

East: 0.00097

Precision 1: 871,017.143

Lot 1 Parcel 2

Segment# 1: Line

Course: N50° 45' 13.52"E

Length: 20.333'

North: 3,779.9991'

East: -8,253.5290'

Segment# 2: Line

Course: S39° 14' 46.48"E

Length: 5.346'

North: 3,775.8589'

East: -8,250.1468'

Segment# 3: Line

Course: N50° 45' 13.52"E

Length: 21.161'

North: 3,789.2465'

East: -8,233.7590'

Segment# 4: Line

Course: S47° 38' 48.05"E

Length: 16.852'

North: 3,777.8933'

East: -8,221.3053'

Segment# 5: Curve

Length: 289.883'

Radius: 439.600'

Delta: 37°46'56.11"

Tangent: 150.433'

Chord: 284.659'

Course: N65° 52' 55.82"E

Course In: N5° 13' 36.12"W

Course Out: S43° 00' 32.24"E

RP North: 4,215.6655'

East: -8,261.3514'

End North: 3,894.2093'

East: -7,961.4947'

Segment# 6: Line

Course: S43° 00' 32.24"E

North: 3,887.6281'

Length: 9.000'

East: -7,955.3557'

Segment# 7: Curve

Length: 344.666'

Delta: 44°01'16.12"

Chord: 336.251'

Course In: N43° 00' 32.24"W

RP North: 4,215.6655'

End North: 3,767.1355'

Radius: 448.600'

Tangent: 181.342'

Course: S69° 00' 05.82"W

Course Out: S1° 00' 43.88"W

East: -8,261.3514'

East: -8,269.2760'

Perimeter: 707.241'

Error Closure: 0.0005

Error North : 0.00021

Precision 1: 1,414,482.000

Area: 3,213.77Sq.Ft.

Course: N63° 07' 40.52"W

East: -0.00041

Lot 11 Parcel 1

Segment# 1: Curve

Length: 8.661'

Delta: 1°06'22.10"

Chord: 8.660'

Course In: N41° 54' 05.00"W

RP North: 4,238.6304'

End North: 3,910.5854'

Radius: 448.600'

Tangent: 4.330'

Course: N47° 32' 43.95"E

Course Out: S43° 00' 27.10"E

East: -8,207.2620'

East: -7,901.2744'

Segment# 2: Line

Course: S43° 03' 52.35"E

North: 3,866.8715'

Length: 59.834'

East: -7,860.4184'

Segment# 3: Line

Course: S39° 21' 33.08"E

North: 3,664.2405'

Length: 262.073'

East: -7,694.2170'

Segment# 4: Line
Course: S34° 00' 27.78"E Length: 22.943'
North: 3,645.2216' East: -7,681.3849'

Segment# 5: Line
Course: N44° 25' 36.00"W Length: 50.705'
North: 3,681.4324' East: -7,716.8782'

Segment# 6: Line
Course: N40° 30' 34.00"W Length: 293.710'
North: 3,904.7398' East: -7,907.6644'

Perimeter: 697.926' Area: 2,894.23Sq.Ft.
Error Closure: 0.0003 Course: N30° 31' 04.74"W
Error North : 0.00029 East: -0.00017
Precision 1: 2,326,420.000

Lot 11 Parcel 2

Segment# 1: Line
Course: S49° 58' 37.00"W Length: 10.523'
North: 3,522.2808' East: -7,089.1241'

Segment# 2: Line
Course: N0° 29' 34.72"E Length: 13.280'
North: 3,535.5603' East: -7,089.0098'

Segment# 3: Line
Course: N78° 34' 25.74"E Length: 8.176'
North: 3,537.1800' East: -7,080.9959'

Segment# 4: Line
Course: S0° 29' 34.72"W Length: 8.132'
North: 3,529.0483' East: -7,081.0658'

Perimeter: 40.111'
Error Closure: 0.0002
Error North : 0.00022
Precision 1: 200,555.000

Area: 85.65Sq.Ft.
Course: N26° 53' 42.09"W
East: -0.00011

Lot 12 Parcel 1

Segment# 1: Curve

Length: 85.677'	Radius: 448.600'
Delta: 10°56'34.15"	Tangent: 42.969'
Chord: 85.547'	Course: N85° 32' 26.80"E
Course In: N1° 00' 43.88"E	Course Out: S9° 55' 50.27"E
RP North: 4,112.0199'	East: -8,269.3885'
End North: 3,670.1412'	East: -8,192.0249'

Segment# 2: Line

Course: S75° 51' 00.83"W	Length: 45.459'
North: 3,659.0284'	East: -8,236.1047'

Segment# 3: Line

Course: S57° 41' 41.51"W	Length: 24.364'
North: 3,646.0076'	East: -8,256.6975'

Segment# 4: Line

Course: S77° 48' 31.33"W	Length: 17.157'
North: 3,642.3844'	East: -8,273.4675'

Segment# 5: Line

Course: S50° 59' 55.69"W	Length: 2.728'
North: 3,640.6676'	East: -8,275.5876'

Segment# 6: Line

Course: S0° 00' 00.00"E	Length: 25.881'
North: 3,614.7866'	East: -8,275.5876'

Segment# 7: Line

Course: S89° 57' 14.56"W	Length: 8.000'
North: 3,614.7802'	East: -8,283.5876'

Segment# 8: Line
Course: N0° 00' 00.00"E Length: 18.311'
North: 3,633.0912' East: -8,283.5876'

Segment# 9: Line
Course: N39° 00' 04.31"W Length: 13.186'
North: 3,643.3385' East: -8,291.8860'

Segment# 10: Line
Course: N50° 59' 55.69"E Length: 24.033'
North: 3,658.4633' East: -8,273.2092'

Segment# 11: Line
Course: N39° 14' 46.48"W Length: 6.489'
North: 3,663.4886' East: -8,277.3144'

Perimeter: 271.284' Area: 1,089.39Sq.Ft.
Error Closure: 0.0019 Course: S45° 40' 30.74"W
Error North : -0.00132 East: -0.00135

Precision 1: 142,781.579

Lot 14 Parcel 1

Segment# 1: Line
Course: N50° 24' 16.76"E Length: 169.401'
North: 3,065.8762' East: -7,550.0191'

Segment# 2: Line
Course: N49° 50' 46.76"E Length: 217.709'
North: 3,206.2636' East: -7,383.6203'

Segment# 3: Line
Course: S39° 53' 10.47"E Length: 3.000'
North: 3,203.9617' East: -7,381.6965'

Segment# 4: Line
Course: S50° 05' 26.34"W Length: 379.184'

North: 2,960.6868' East: -7,672.5535'

Segment# 5: Line

Course: S0° 00' 00.00"E

Length: 72.491'

North: 2,888.1958'

East: -7,672.5535'

Segment# 6: Line

Course: S50° 00' 00.00"W

Length: 18.745'

North: 2,876.1467'

East: -7,686.9130'

Segment# 7: Line

Course: S40° 00' 00.00"E

Length: 5.693'

North: 2,871.7856'

East: -7,683.2537'

Segment# 8: Line

Course: S50° 00' 00.00"W

Length: 18.251'

North: 2,860.0541'

East: -7,697.2347'

Segment# 9: Line

Course: N40° 00' 00.00"W

Length: 15.332'

North: 2,871.7991'

East: -7,707.0900'

Segment# 10: Line

Course: N50° 00' 00.00"E

Length: 18.252'

North: 2,883.5312'

East: -7,693.1081'

Segment# 11: Line

Course: S40° 00' 00.00"E

Length: 1.640'

North: 2,882.2749'

East: -7,692.0539'

Segment# 12: Line

Course: N50° 00' 00.00"E

Length: 15.013'

North: 2,891.9251'

East: -7,680.5533'

Segment# 13: Line

Course: N0° 00' 00.00"E

Length: 65.980'

North: 2,957.9051'

East: -7,680.5533'

Perimeter: 1,000.691'

Area: 1,938.49Sq.Ft.

Error Closure: 0.0014
Error North : -0.00139
Precision 1: 714,779.286

Course: S11° 26' 37.19"E
East: 0.00028

Lot 14 Parcel 2

Segment# 1: Line

Course: N49° 59' 42.00"E
North: 3,291.8896'

Length: 8.000'
East: -7,564.3280'

Segment# 2: Line

Course: S39° 53' 10.47"E
North: 3,280.0568'

Length: 15.421'
East: -7,554.4390'

Segment# 3: Line

Course: S49° 50' 46.76"W
North: 3,274.8980'

Length: 8.000'
East: -7,560.5536'

Segment# 4: Line

Course: N39° 53' 10.47"W
North: 3,286.7470'

Length: 15.442'
East: -7,570.4560'

Perimeter: 46.864'

Area: 123.45Sq.Ft.

Error Closure: 0.0003

Course: N23° 41' 05.18"W

Error North : 0.00023

East: -0.00010

Precision 1: 156,210.000

Lot 14 Parcel 3

Segment# 1: Line

Course: S49° 50' 46.76"W
North: 3,250.6475'

Length: 90.526'
East: -7,371.0907'

Segment# 2: Line

Course: N44° 14' 25.53"E
North: 3,296.1458'

Length: 63.508'
East: -7,326.7830'

Segment# 3: Line

Course: N59° 16' 32.98"E
North: 3,305.2332'

Length: 17.787'
East: -7,311.4926'

Segment# 4: Line

Course: N68° 26' 45.24"E
North: 3,309.0224'

Length: 10.314'
East: -7,301.8999'

Perimeter: 182.136'

Error Closure: 0.0002

Error North : 0.00016

Area: 295.42Sq.Ft.

Course: N47° 13' 02.60"E

East: 0.00017

Precision 1: 910,675.000

Lot 14 Parcel 4

Segment# 1: Line

Course: N65° 43' 15.81"E
North: 3,322.9564'

Length: 70.644'
East: -7,227.8928'

Segment# 2: Line

Course: N55° 17' 23.85"E
North: 3,373.1722'

Length: 88.187'
East: -7,155.3991'

Segment# 3: Line

Course: N47° 02' 48.39"E
North: 3,437.3540'

Length: 94.191'
East: -7,086.4598'

Segment# 4: Line

Course: N0° 29' 34.72"E
North: 3,491.6070'

Length: 54.255'
East: -7,085.9930'

Segment# 5: Line

Course: N49° 58' 37.00"E
North: 3,498.3743'

Length: 10.523'
East: -7,077.9346'

Segment# 6: Line

Course: S0° 29' 34.72"W
North: 3,433.8437'

Length: 64.533'
East: -7,078.4899'

Segment# 7: Line

Course: S47° 02' 48.39"W

North: 3,366.9240'

Length: 98.209'

East: -7,150.3700'

Segment# 8: Line

Course: S55° 17' 23.85"W

North: 3,315.9640'

Length: 89.494'

East: -7,223.9381'

Segment# 9: Line

Course: S65° 43' 15.81"W

North: 3,285.8336'

Length: 73.278'

East: -7,290.7349'

Segment# 10: Line

Course: S68° 26' 45.24"W

North: 3,282.5691'

Length: 8.886'

East: -7,298.9996'

Segment# 11: Line

Course: N49° 50' 46.76"E

North: 3,288.0773'

Length: 8.542'

East: -7,292.4708'

Segment# 12: Line

Course: N1° 47' 00.76"E

North: 3,293.9085'

Length: 5.834'

East: -7,292.2892'

Perimeter: 666.577'

Error Closure: 0.0008

Error North : -0.00061

Precision 1: 833,220.000

Area: 2,548.54Sq.Ft.

Course: S42° 39' 36.54"W

East: -0.00057

